

QueueWay Retractable Barrier

Solutions from QueueWay offer a cost-effective way to ensure safe queuing in any environment. The QueueWay Post is an economy crowd control barrier, which features 2.3m webbing. Ideal for a variety of applications.

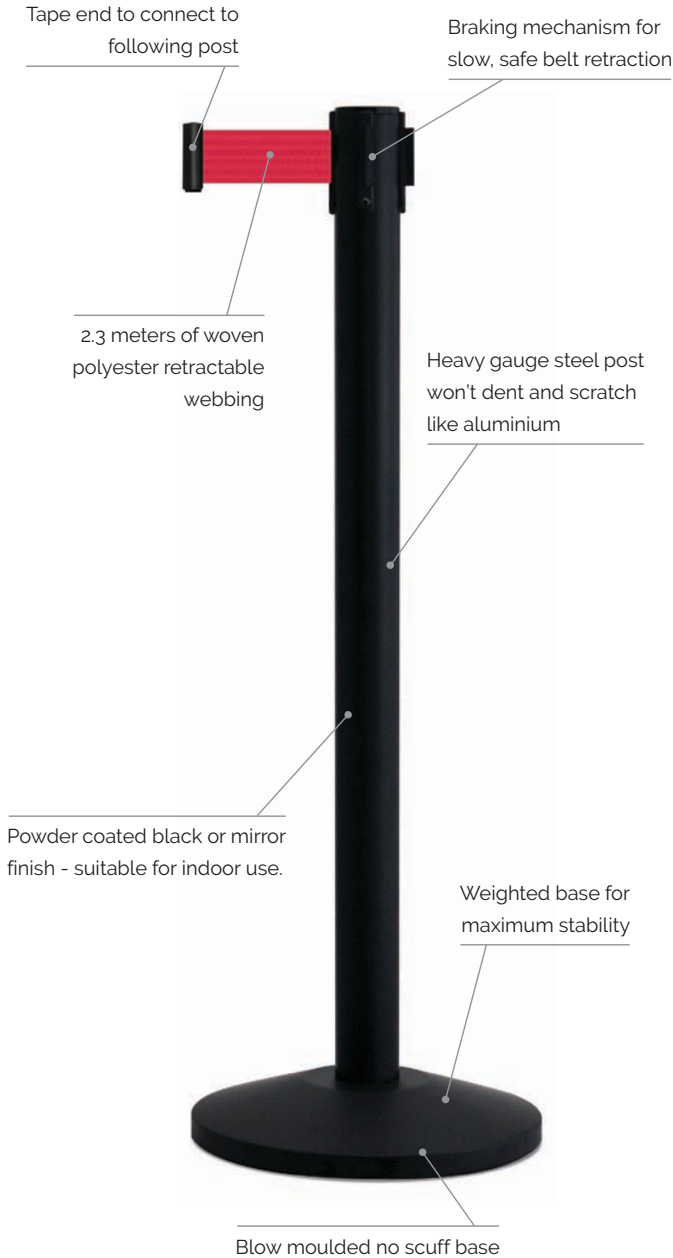
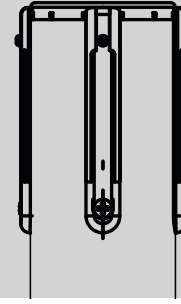

Features & Benefits

- 2.3m of Black, Blue, Red, Yellow/Black Chevron Webbing.
- Post and base available in two colours - Black or Mirror Finish.
- Heavy gauge steel post won't dent and scratch like aluminium.
- Effective built-in braking system for slow, safe webbing retraction.
- Full weight 356mm diameter base for maximum stability.
- Full circumference rubber floor protector for maximum protection against floor scuffing.
- Posts sold and shipped in pairs.
- Posts distributed flat packed and are assembled within seconds without the use of tools.
- Not compatible with TensabARRIER® posts.
- Accommodates Tensator's range of sign holders.

Post Finishes



Webbing Options

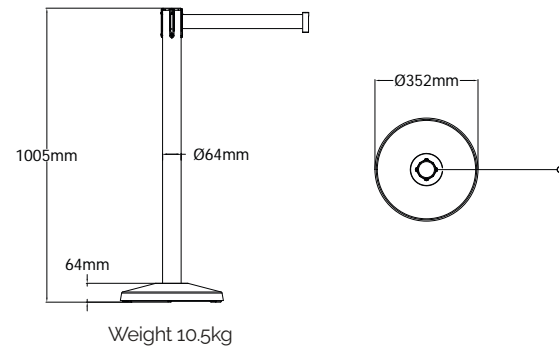
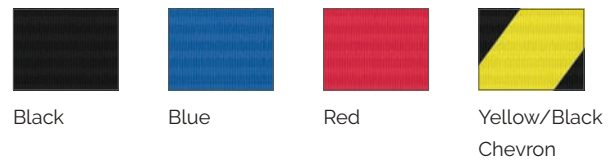

Order Code

- QWYPOST-33 - QueueWay Pair in Black
- QWYPOST-1P - QueueWay Pair in Mirror Finish